

GM3 LOCKPICK PRO PLUS STANDARD INSTALLATION

COPYRIGHT 2017 COASTAL ELECTRONIC TECHNOLOGIES, INC.

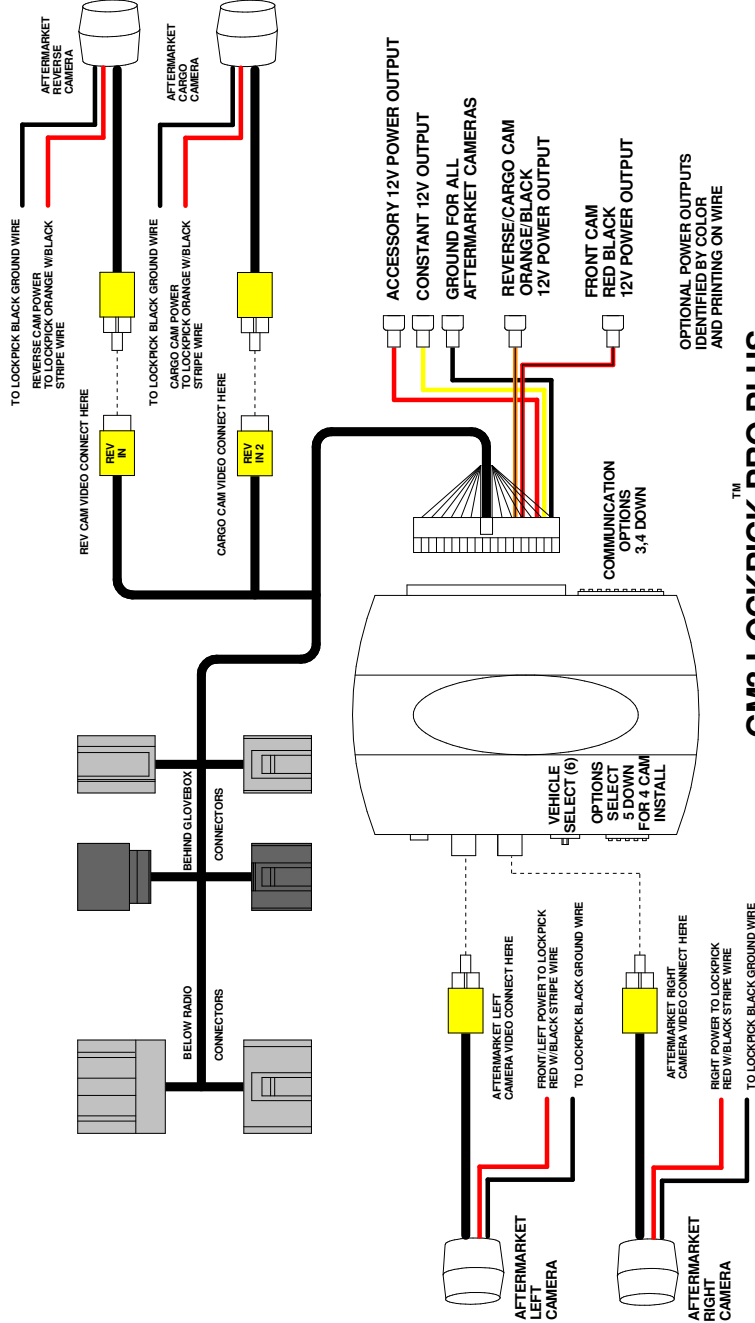

GM3 LOCKPICK PRO PLUS LEFT/RIGHT TURN CAMERA INSTALLATION

COPYRIGHT 2017 COASTAL ELECTRONIC TECHNOLOGIES, INC.



VEHICLE SELECT
SET FOR 6

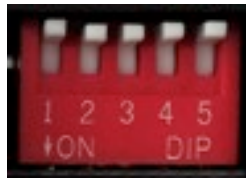

STANDARD
INSTALLATION



LEFT/RIGHT
TURN CAMERAS



COMMUNICATION SWITCHES
PLACE 3, 4 DOWN

Place vehicle option switches in the correct position before plugging module into Lockpick harness. If you desire to change a setting, unplug module first.

Installation: The Lockpick is designed to be Plug-N-Play with a simple "T" harness that goes in between the factory connectors and the vehicle module. No other connections are necessary however, your harness will contain additional outputs which you may use to power and supply ground for your aftermarket cameras or additional accessories. Each output is rated for 1.5 amps.

A full video detailing Lockpick installation and operation is available at the following link: <https://www.youtube.com/watch?v=K20htWG3-Cw> Installations may vary slightly between vehicles. The Lockpick harness connectors are uniquely shaped and keyed so they will not fit in the wrong location.

Begin by lowering the glove box. Release the side tension clip, then squeeze the glove box sides to fully lower and expose a factory module behind.

Plug in Lockpick harness with 2 connectors at location shown

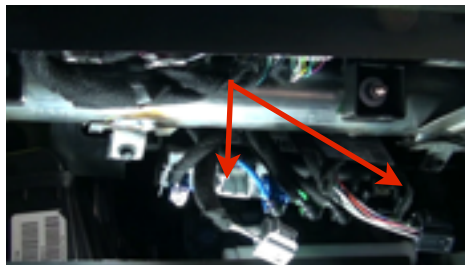

Lift up center console and slide back to expose factory module below radio.

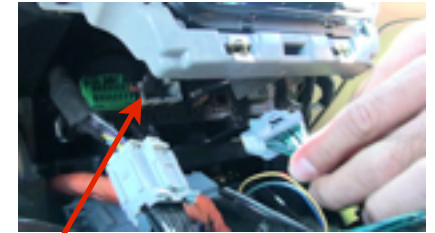
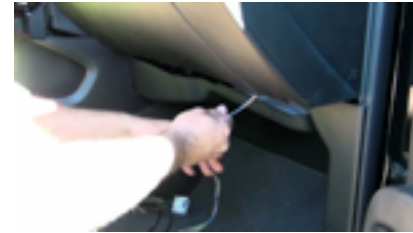

Remove screws from panel below glove box. Route Lockpick harness down right side of glove box and over to center console. Pass part of harness with gray connectors into the console area below the radio. Disconnect connector shown and plug in Lockpick connector.



Set Lockpick option switches properly and plug the Lockpick module into the Lockpick harness. Place the module in the space below the glove box and reassemble.



The Lockpick is activated by pressing the rear defrost button 2x. Lockpick menu will appear controlled by the touch screen. Additional Options turn on or off automatic functions,